



Planetary Mixers Planetary Mixer, 10 Lt. - Mechanical

ITEM # _____

MODEL # _____

NAME # _____

SIS # _____

AIA # _____



600141 (DXBM10B)

10 Lt planetary mixer, bowl detection device, mechanical speed variation. Equipped with spiral hook, paddle and whisk. Equipped with highly resistant safety screen - BPA free

Short Form Specification

Item No. _____

Suitable for all kneading, blending and whipping operations. Body, feet and 10 litre capacity bowl in stainless steel. Powerful asynchronous motor (500 W) with mechanical speed variator (8 speed levels from 30 to 170 rpm). Water protected planetary system. Removable/transparent solid safety screen - made of a bisphenol-A free (BPA) copolyester. Water proof (IP55) and flat touch button control panel with 60 min. timer. Bowl detection device allows the mixer to switch on only when the bowl and the safety screen are properly installed and positioned together. Adjustable feet for stability. Supplied with 3 tools: spiral hook, paddle and whisk.

Main Features

- Professional beater mixer that provides all the basic mixer functions: kneading of all sort of pastes, mixing of semi-liquid products, emulsions and various sauces.
- Bowl detection device allows the mixer to switch on only when the bowl and the solid safety screen are properly installed and positioned together.
- Maximum capacity (flour, with 60% of hydration) 3.5 kg, suitable for 10-50 meals per service.
- Removable safety screen activates the raising and lowering of the bowl.
- Mechanical speed variator.
- Delivered with:
 - Spiral Hook, Paddle, Wire Whisk and Mixing Bowl for 10 lt

Construction

- Sturdy construction with mechanically welded strong metal frame.
- Compact design for table top installations.
- Adjustable feet for perfect stability.
- Body entirely in stainless steel.
- Asynchronous motor with high start-up torque.
- Power: 500 Watts.
- Planetary movement based on self lubricating gears, eliminating any risk of leaks.
- Water protected planetary system (IP55 electrical controls, IP34 appliance overall).
- 8 speeds, from 30 to 170 rpm, to be lever operated while the machine is working, according to the tool and the mixture hardness.
- AISI 302 stainless steel bowl - 10 lt. capacity.
- Waterproof touch button control panel with timer setting, display and pulse function.

Included Accessories

- 1 of PADDLE FOR 10LT MIXER PNC 653267
- 1 of DOUGH HOOK FOR 10LT MIXER PNC 653268
- 1 of WHISK FOR 10LT MIXER PNC 653269
- 1 of BOWL FOR 10LT MIXER PNC 653276

Optional Accessories

- PADDLE FOR 10LT MIXER PNC 653267
- DOUGH HOOK FOR 10LT MIXER PNC 653268
- WHISK FOR 10LT MIXER PNC 653269
- BOWL FOR 10LT MIXER PNC 653276

APPROVAL: _____

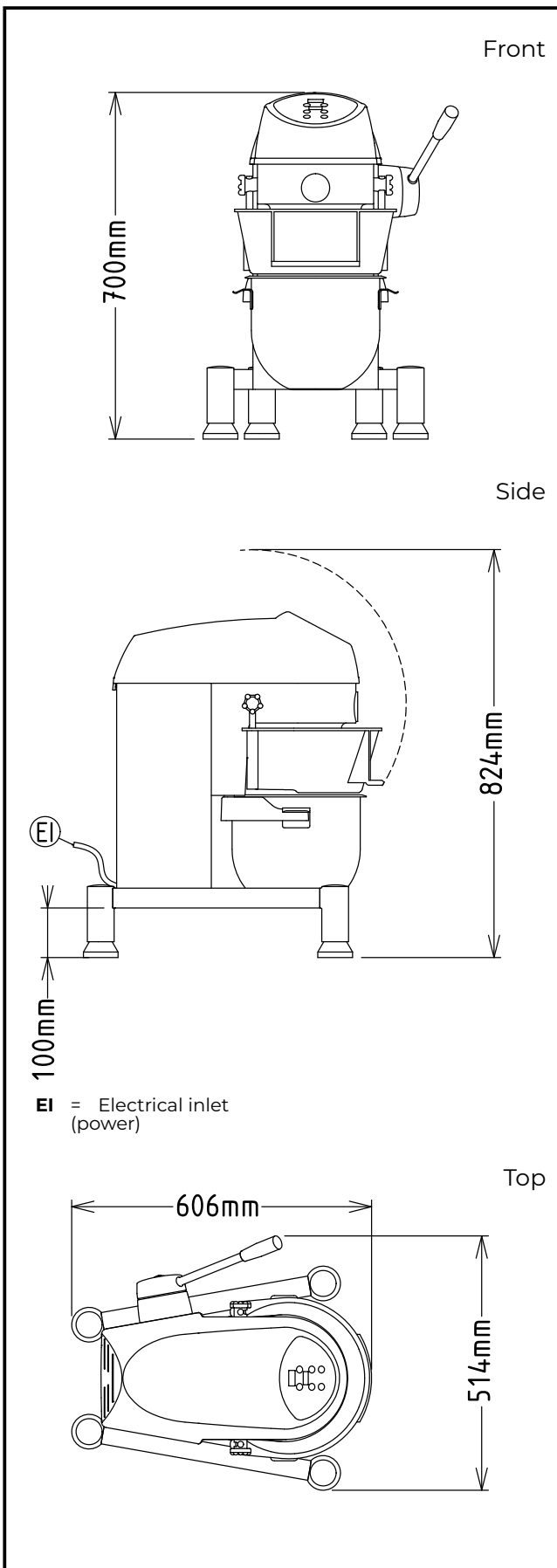

Electric

Supply voltage: 380-415 V/3 ph/50 Hz
Electrical power max.: 0.5 kW
Total Watts: 0.5 kW

Capacity:

Performance (up to): 3.5 kg/Cycle
Capacity: 10 litres

Key Information:

External dimensions, Width: 454 mm
External dimensions, Depth: 606 mm
External dimensions, Height: 700 mm
Shipping weight: 57 kg
Net weight (kg): 45
Cold water paste: 3.5 kg with Spiral hook
Egg whites: 18 with Whisk